

Hydraulic clamp VB

Catalogue n° 2406UK-bl

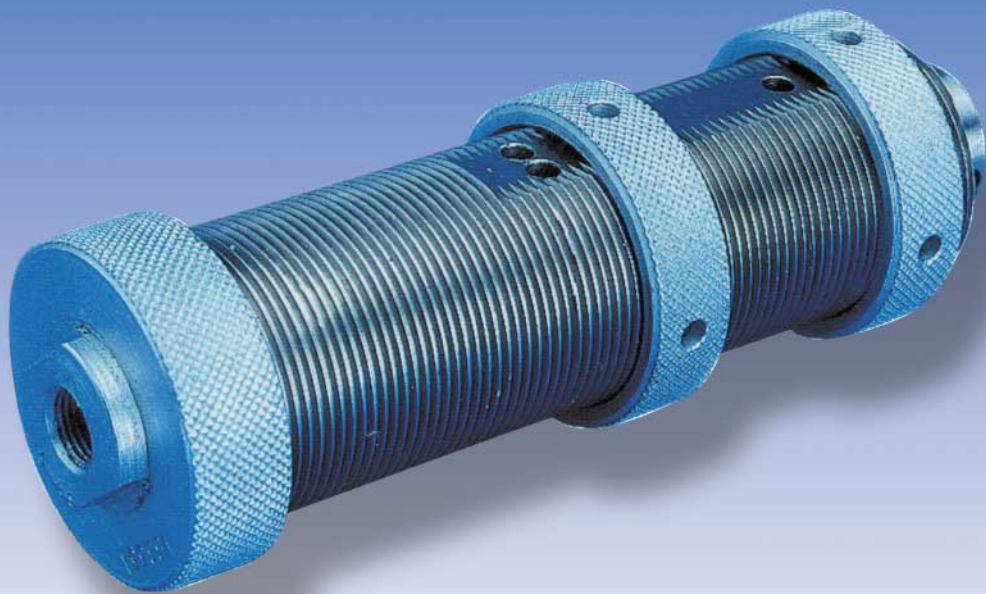

Description

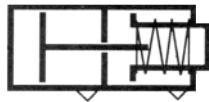

Clamp cylinders are single acting pneumatic cylinders with built-in air-oil intensifiers. They can be used to solve most clamping, tightening, etc problems :

- compact size for large forces exerted (up to 2 700 daN depending on the model and air pressure)
- operated using a compressed air supply (no special installation required)
- easy adjustment thanks to a fully threaded body
- simple and rapid installation

Clamping examples

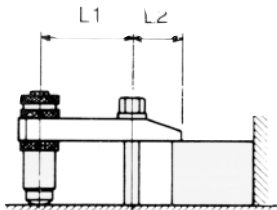

Clamping with intensified force
 $L1/L2 < 2$

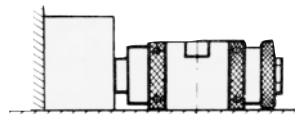

Horizontal clamping

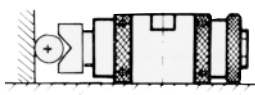

Clamping of cylindrical component using V groove clamp end

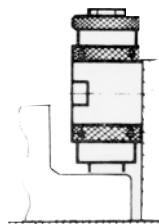

Vertical clamping

Hydraulic clamp

Order Codes

Model No.	Max. stroke (mm)	Ø external	Weight – g (lbs)
VB363C	3	36	570 (1.3)
VB366C	6	36	640 (1.4)
VB369C	9	36	890 (2.0)
VB483C	3	48	1 050 (2.3)
VB486C	6	48	1 350 (3.0)
VB489C	9	48	1 152 (2.5)
VB4812C	12	48	1 840 (4.0)
VBH483C	3	48	1 240 (2.7)
VB606C	6	60	2 360 (5.2)
VB609C	9	60	3 120 (6.9)
VB6012C	12	60	3 810 (8.4)
VBH603C	3	60	2 360 (5.2)
VBH606C	6	60	3 700 (8.1)

Mounting accessories

Mounting for VB	Mounting block	Rounded end	V groove end
Ø36	FVA36-1	BVA36-16	BVA36-17
Ø48	FVA48-1	BVA48-16	BVA48-17
Ø60	FVA60-1	BVA60-16	BVA60-17

Maintenance

For all operations see our maintenance instructions
All safety requirements must be observed

Seal kit for	VB Ø 36	VB Ø 48	VBH Ø 48	VB Ø 60	VBH Ø 60
Model No.	JJVB36	JJVB48	JJVBH48	JJVB60	JJVBH60

Oil container suitable for all types of cylinder (250 ml capacity)
Model No. : BH680VB

Technical Information

Material specification

Body	Nickel plated steel
Piston rod	Hardened steel
Locking rings	Zinc plated steel
End cap	Zinc plated steel
Seals	Nitrile

Operation

Temperature range	+5°C to +50°C (41°F to 122°F)
Storage temperature	-20°C to +60°C (-4°F to 140°F)
Pressure range	1 to 9 bar (15 to 130 psi) (except VBH603 and VBH606 : 7 bar (101psi max.))
Air condition	Filtered air 40 µ lubricated or non lubricated

Technical Information

Cylinder forces

Note : The clamping time is given from the moment the clamp cylinder is pressurised to the time at when 90% of the clamping force is obtained, the cylinder completing a full stroke

The release time is given from the moment the clamp cylinder starts to exhaust until the rod is fully retracted

When the cylinder remains pressurised for more than 10 min. add 0,20 sec. to the release time

These average times are given for information only . They will vary depending on the application and the cylinder inlet and exhaust circuits

Model No.	Max. stroke (mm)	Force at 6 bar daN (lbs)	Clamping time (s)	Release time (s)
VB363C	3	240 (540)	0,10	1,00
VB366C	6	240 (540)	0,15	1,30
VB369C	9	240 (540)	0,20	1,50
VB483C	3	530 (1 190)	0,30	1,30
VB486C	6	530 (1 190)	0,40	1,60
VB489C	9	530 (1 190)	0,50	1,90
VB4812C	12	530 (1 190)	0,60	2,20
VBH483C	3	1 060 (2 380)	0,50	0,70
VB606C	6	1 140 (2 560)	0,50	1,90
VB609C	9	1 140 (2 560)	0,60	2,30
VB6012C	12	1 140 (2 560)	0,70	2,50
VBH603C	3	1 800 (4 000)	0,50	0,70
VBH606C	6	1 800 (4 000)	0,60	1,05

Principle of operation

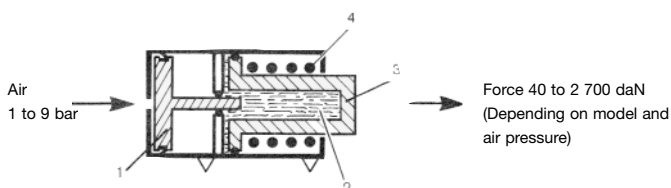

Air pressure applied to the pneumatic piston (1) causes the plunger to displace the enclosed oil in the hydraulic section of the cylinder (2) . A high-pressure stroke results at the hydraulic piston (3) due to the differential areas of the two pistons

The return of pistons (1) and (3) is caused by a return spring (4) when the air pressure is removed

Hydraulic Clamp

Technical Information

Working conditions

Clamp cylinders must be installed so that the force is directed along the axis. (Take care that the exhaust ports are not blocked and that they are protected from swarf, cutting oil, dust, etc...)

Do not operate the cylinder at no-load. The clamp cylinder must always be operated in conjunction with a clamping fixture (clamp or block) to limit the stroke to within the maximum length specified in the ordering reference table above

We recommend an effective stroke equal to the max. length minus 1 mm

Please contact us for applications requiring force during part of the stroke (marking, crimping, punching, etc...) and high speeds

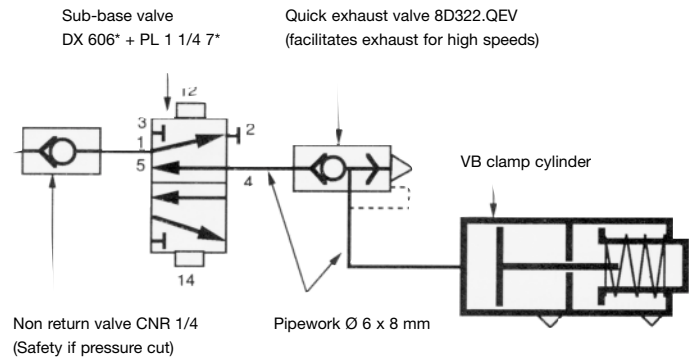

Connection

For correct use of clamp cylinders, we recommend application of the circuit diagram opposite :

Dimensions (mm)

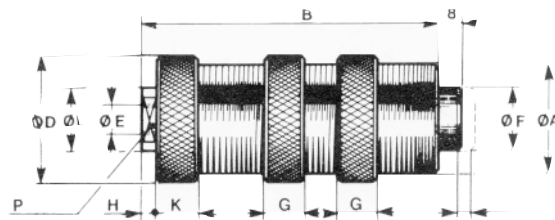

Model No	ØA	B	ØD	ØE	ØF	G	H	K	ØL	P
VB363C	M36 x 1,5	98,0	42	G1/8	22	12	4	13	22	17
VB366C	M36 x 1,5	127,5	42	G1/8	22	12	4	13	22	17
VB369C	M36 x 1,5	185,0	42	G1/8	22	12	4	13	22	17
VB483C	M48 x 1,5	111,0	56	G1/8	32	12	4	13	22	17
VBH483C	M48 x 1,5	148,0	56	G1/8	32	12	4	13	22	17
VB486C	M48 x 1,5	148,0	56	G1/8	32	12	4	13	22	17
VB489C	M48 x 1,5	188,0	56	G1/8	32	12	4	13	22	17
VB4812C	M48 x 1,5	234,0	56	G1/8	32	12	4	13	22	17
VBH603C	M60 x 2	175,0	70	G1/4	40	14	5	17	25	22
VB606C	M60 x 2	175,0	70	G1/4	40	14	5	17	25	22
VBH606C	M60 x 2	290,0	70	G1/4	40	14	5	17	25	22
VB609C	M60 x 2	249,0	70	G1/4	40	14	5	17	25	22
VB6012C	M60 x 2	314,0	70	G1/4	40	14	5	17	25	22

Dimensions (mm)

Mounting accessories

Mounting block

For VB	Model No.	A	B	C	ØD	E	F	G	P	R	ØV
Ø 36	FVA36-1	24,0	38,0	50,0	36,2	54,0	18,0	-	40,0	70,0	11,0
Ø 48	FVA48-1	30,0	47,0	60,0	48,2	70,0	20,0	-	50,0	90,0	13,5
Ø 60	FVA60-1	36,0	57,0	70,0	60,2	90,0	20,0	36,0	60,0	110,0	13,5

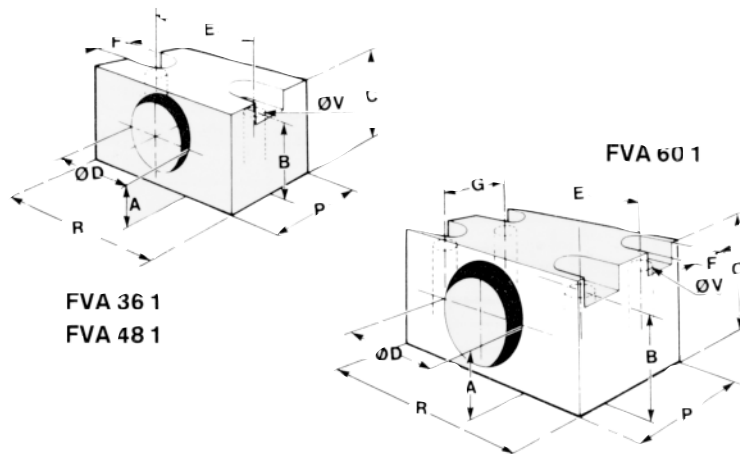

Rounded clamp piston end

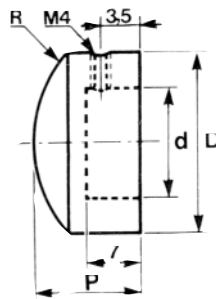
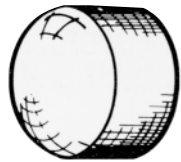

V groove clamp piston end

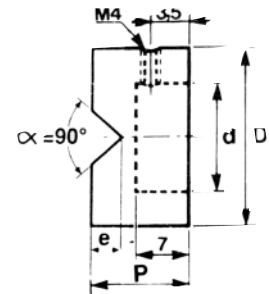
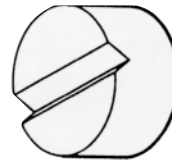

Dimensions (mm)

For VB	Model No.	d	R	P	D
Ø 36	BVA36-16	22	25	15	30
Ø 48	BVA48-16	32	40	15	40
Ø 60	BVA60-16	40	50	18	50

Dimensions (mm)

For VB	Model No.	d	e	P	D
Ø 36	BVA36-17	22	5	15	30
Ø 48	BVA48-17	32	5	15	40
Ø 60	BVA60-17	40	8	18	50